

REV.	DESCRIPTION	DATE	BY

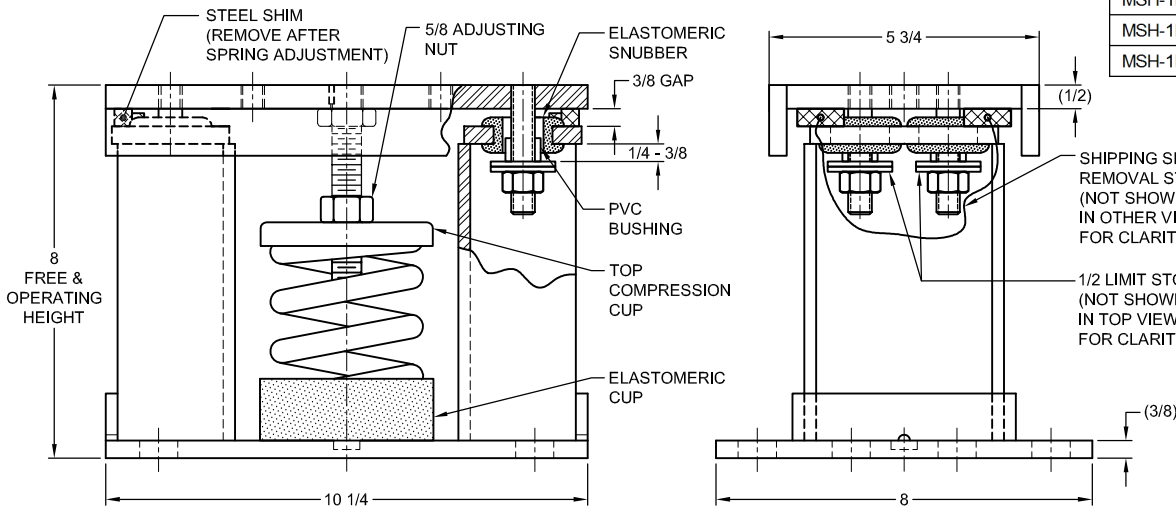

MODEL MSH-1E SEISMICALLY RESTRAINED VIBRATION ISOLATOR FOR 1" DEFLECTION					
SEISMIC MOUNT SIZE	RATED LOAD (LBS)	RATED DEFLECTION (IN)	SPRING RATE (LBS/IN)	SLCID LOAD (LBS)	COLOR CODE
MSH-1E-195	195	1.95	100	294	DK BLUE
MSH-1E-400	400	1.32	303	630	BLACK
MSH-1E-530N	530	1.17	453	795	BLACK/ DK BLUE
MSH-1E-650	650	1.05	620	1380	RED
MSH-1E-825N	825	1.07	769	1349	RED/ DK BLUE
MSH-1E-1000	1000	1.00	1000	1630	TAN
MSH-1E-1200N	1200	1.04	1150	1875	TAN/ DK BLUE
MSH-1E-1400	1400	1.00	1400	2578	PINK
MSH-1E-1700N	1700	1.10	1550	2719	PINK/ DK BLUE
MSH-1E-2000	2000	1.11	1800	3010	WHITE
MSH-1E-2575N	2575	1.11	2313	3867	WHITE/ DK PURPLE
MSH-1E-2990N	2990	1.11	2682	4484	WHITE/ DK GREEN
MSH-1E-3250N	3250	1.04	3125	4875	WHITE/ GRAY

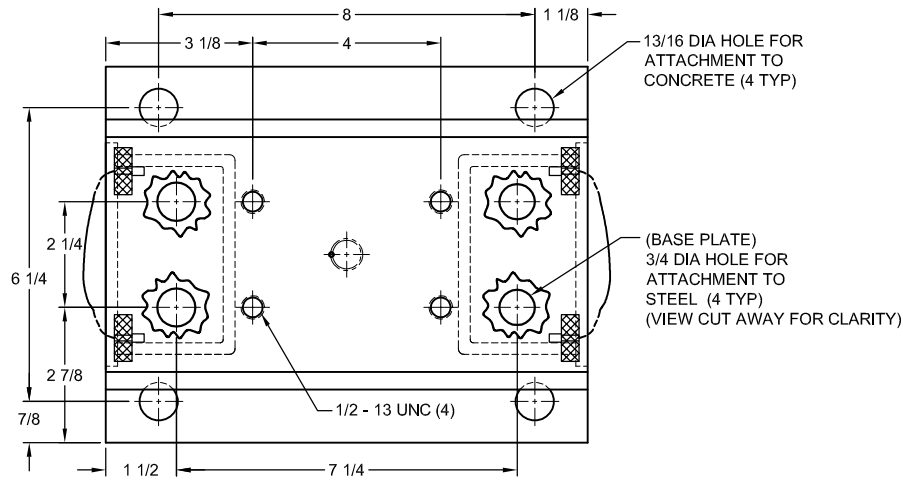
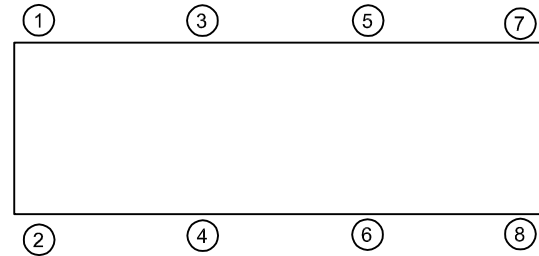

- NOTES:
- ALL DIMENSIONS ARE IN INCHES, INTERPRET PER ANSI Y14.
 - STANDARD FINISH: HOUSING - POWDER COAT (COLOR:BLACK), SPRING - POWDER COAT (COLOR: SEE TABLE), HARDWARE ZINC-ELECTROPLATE.
 - EQUIPMENT MUST BE BOLTED OR WELDED TO THE TOP AND BOTTOM PLATE TO MEET ALLOWABLE SEISMIC RATINGS.
 - MOST SPRINGS ARE DESIGNED FOR 50% OVERLOAD CAPACITY.
 - REFER TO SHEET 2 OF 2 FOR INSTALLATION INSTRUCTIONS.
 - RATED DEFLECTIONS ARE WITHIN 25% OF NOMINAL. HIGHER DEFLECTIONS ARE ALLOWED IF THEY MEET SPECIFICATIONS.

ISOLATOR SELECTIONS	
LOC 1:	LOC 2:
LOC 3:	LOC 4:
LOC 5:	LOC 6:
LOC 7:	LOC 8:
CUSTOMER EQPT. TAG:	

NOTE: MATERIAL SHOWN IS FOR (1) SET.

OTHER MATERIALS, COMPOUNDS, OR FINISHES WITH EQUAL OR SUPERIOR PROPERTIES MAY BE SUBSTITUTED AS THEY BECOME AVAILABLE.

CERTIFIED FOR:

JOB NAME: _____
 CUSTOMER: _____
 CUSTOMER P.O.: _____
 SALES ORDER: _____

MODEL MSH-1E 195-3250 LBS. VIBRATION ISOLATOR WITH INTEGRAL SEISMIC RESTRAINT AND INTERNAL ADJUSTMENT 1 INCH DEFLECTION



THE VMC GROUP
 The Power of Together
 Bloomingdale, NJ 07403
 Houston, TX 77041

SCALE:

NONE

SHEET:



DRAWING NO.:

REVISION

REV.	DESCRIPTION	DATE	BY

1. READ INSTRUCTIONS IN THEIR ENTIRETY BEFORE BEGINNING INSTALLATION.

- ISOLATORS ARE SHIPPED FULLY ASSEMBLED AND ARE TO BE POSITIONED IN ACCORDANCE WITH THE SUBMITTAL DRAWINGS OR AS OTHERWISE RECOMMENDED.
- SET ISOLATORS ON FLOOR, HOUSEKEEPING PAD, OR SUB-BASE, ENSURING THAT ALL ISOLATOR CENTERLINES MATCH THE SUBMITTAL DRAWING. THE VMC GROUP RECOMMENDS THAT THE ISOLATOR BASE PLATES ("B") BE INSTALLED ON A LEVEL SURFACE. SHIM OR GROUT AS REQUIRED, LEVELING ALL ISOLATOR BASE PLATES AT THE SAME ELEVATION.
- ANCHOR ALL ISOLATORS TO THE FLOOR, HOUSEKEEPING PAD, OR SUB-BASE USING THRU HOLES ("C") FOR CONCRETE OR ("D") FOR STEEL AS REQUIRED. WELDING TO STEEL IS PERMITTED PROVIDING THE WELD ACHIEVES THE REQUIRED STRENGTH.
- ISOLATORS ARE SHIPPED TO THE JOBSITE WITH (2) REMOVABLE SPACER SHIMS ("E") BETWEEN THE TOP PLATE AND THE HOUSING. THESE SHIMS **MUST** BE IN PLACE WHEN THE EQUIPMENT IS POSITIONED OVER THE ISOLATORS.
- WITH ALL SHIMS ("E") IN PLACE, PLACE THE MACHINE OR EQUIPMENT ONTO TOP PLATE ("A") OF THE ISOLATORS. BOLT EQUIPMENT SECURELY TO THE ISOLATORS USING MINIMUM ASTM A325 SAE GR. 5 HIGH-STRENGTH BOLTS BY OTHERS, MEETING THE JOB REQUIREMENTS. WELDING IS PERMITTED PROVIDING THE WELD ACHIEVES THE REQUIRED STRENGTH.

7. THE ADJUSTMENT PROCESS CAN ONLY BEGIN AFTER THE EQUIPMENT OR MACHINE IS AT ITS FULL OPERATING WEIGHT.

- BACK OFF EACH OF THE (2) OR (4) LIMIT STOP LOCKNUTS ("F") PER ISOLATOR 1/4- TO 3/8-INCH.
- ADJUST EACH ISOLATOR IN SEQUENCE BY TURNING ADJUSTING NUT(S) ("G") ONE FULL CLOCKWISE TURN AT A TIME. REPEAT THIS PROCEDURE ON ALL ISOLATORS, ONE AT A TIME. CHECK THE LIMIT STOP LOCKNUTS ("F") PERIODICALLY TO ENSURE THAT CLEARANCE BETWEEN THE WASHER AND RUBBER GROMMET IS MAINTAINED. STOP ADJUSTMENT OF AN ISOLATOR ONLY WHEN THE TOP PLATE ("A") HAS RISEN JUST ABOVE THE SHIM ("E").
- REMOVE ALL SPACER SHIMS ("E").
- FINE ADJUST ISOLATORS TO LEVEL EQUIPMENT.
- ADJUST ALL LIMIT STOP LOCKNUTS ("F") PER ISOLATOR TO OBTAIN 3/8-INCH GAP. THE LIMIT STOP NUTS MUST BE KEPT AT THIS 3/8-INCH GAP TO ENSURE UNIFORM BOLT LOADING DURING UPLIFT.
- INSTALLATION IS COMPLETE.

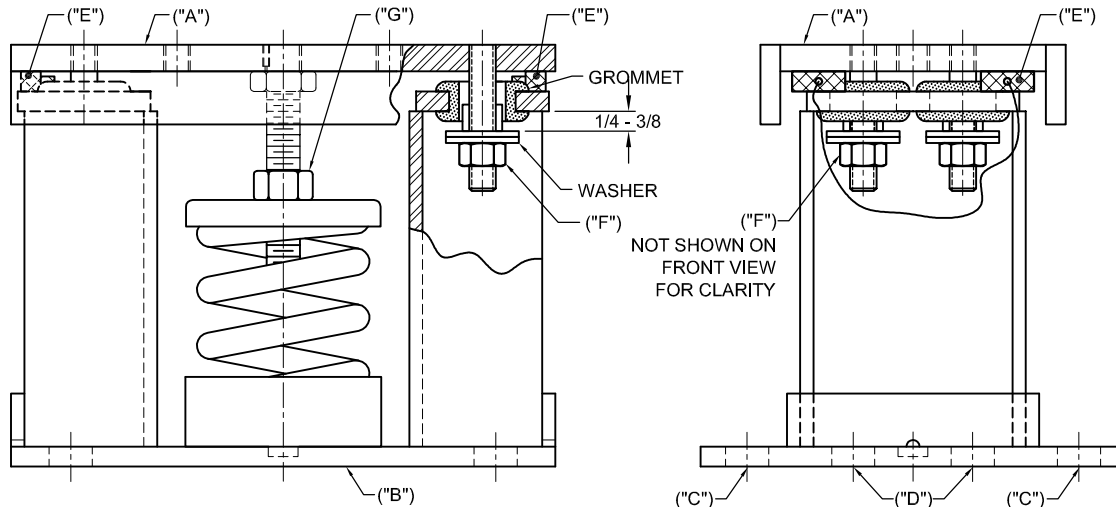

OTHER MATERIALS, COMPOUNDS, OR FINISHES WITH EQUAL OR SUPERIOR PROPERTIES MAY BE SUBSTITUTED AS THEY BECOME AVAILABLE.

CERTIFIED FOR:

JOB NAME: _____
 CUSTOMER : _____
 CUSTOMER P.O.: _____
 SALES ORDER: _____

MODEL MSH-1E 195-3250 LBS. VIBRATION ISOLATOR WITH INTEGRAL SEISMIC RESTRAINT AND INTERNAL ADJUSTMENT 1 INCH DEFLECTION



THE VMC GROUP
The Power of Together
 Bloomingdale, NJ 07403
 Houston, TX 77041

SCALE :

NONE

SHEET:



DRAWING NO.:

REVISION